

Introduction for CIVIC TYPE-R Upgrade

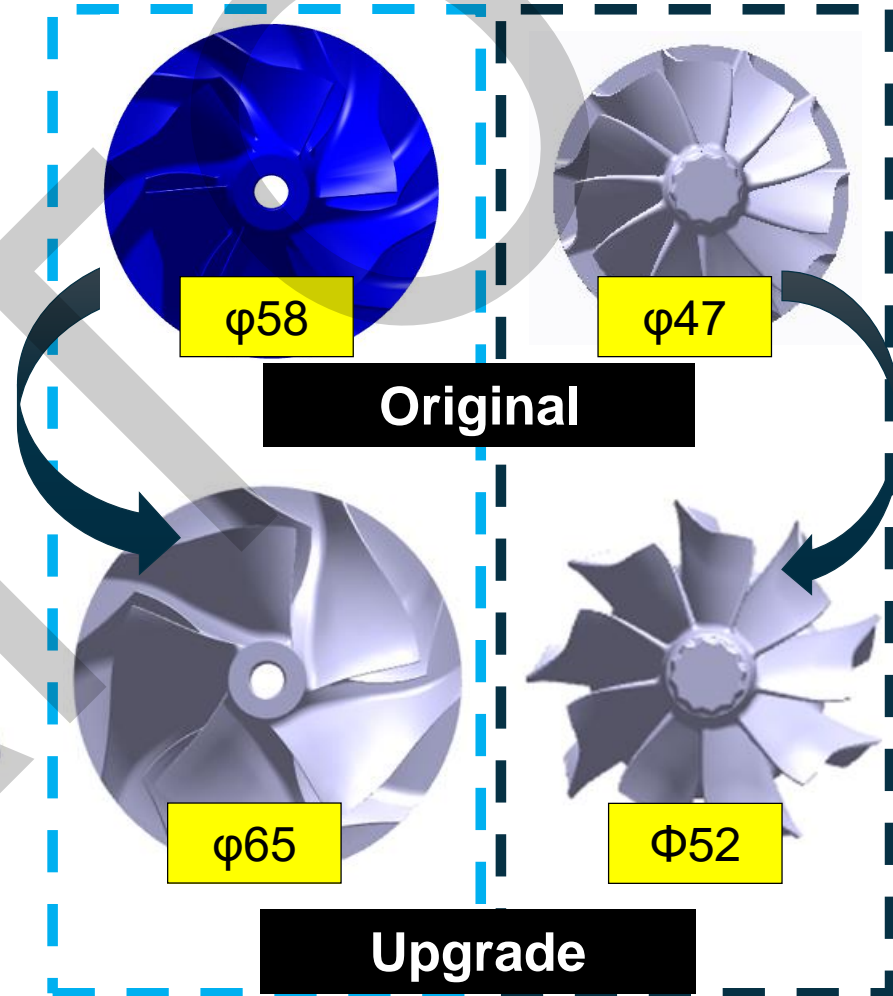

2021/1/25

2. Turbine and Compressor wheels

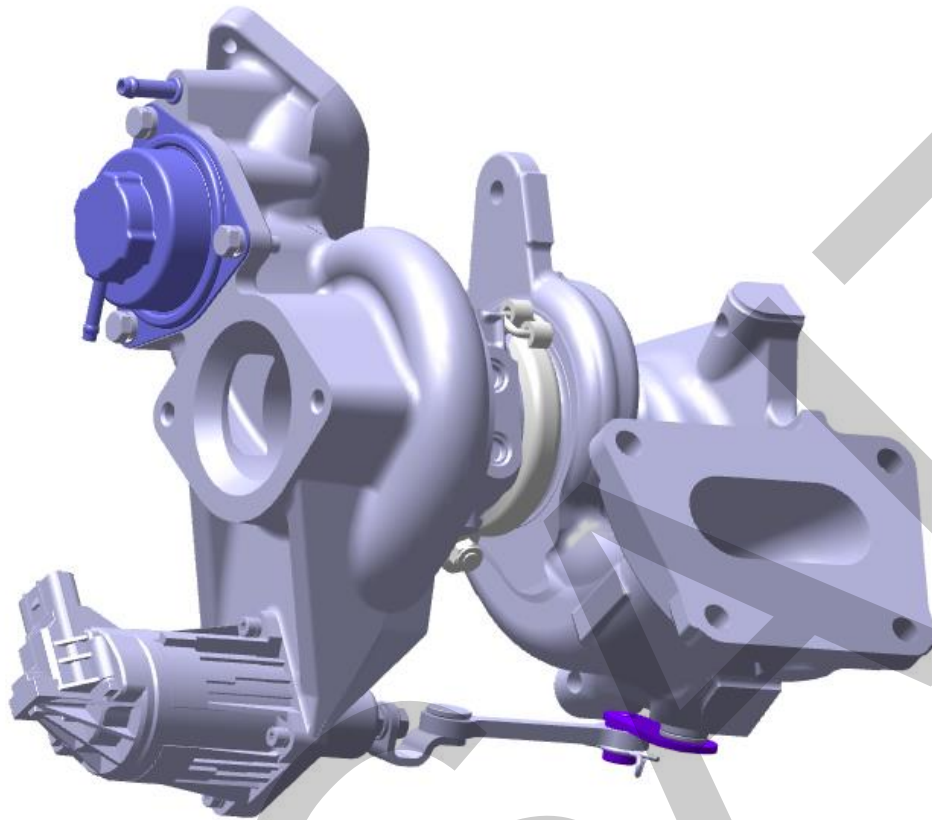

Increased air/gas flow by new design high capacity wheels.

3. Turbo spec comparison

	Upgrade (49S89-A0000)	Original (49477-06012)
Turbo spec	TD04HLL1-05*21HR3-8.5	TD04L6-04H*17HF1p-8.5
Compressor inducer	51.6mm	49.3 mm
Compressor exducer	65 mm	58 mm
Turbine exducer	47.7 mm	41.23 mm
Turbine Inducer	52 mm	47 mm
Engine output (Estimated)	Over 450PS/6500rpm	320PS/6500rpm
Number of blades	Compressor : 10 Turbine : 9	Compressor : 12 Turbine : 11

4. Compressor Map

三菱ターボチャージャ標準コンプレッサ性能曲線
STANDARD COMPRESSOR PERFORMANCE

N

三菱ターボチャージャ標準コンプレッサ性能曲線
STANDARD COMPRESSOR PERFORMANCE

N

Estimated

S-834

型式 MODEL
) TD05/06-21HR3 (φ65)

吸入空気20°C
INLET TEMP.20°C

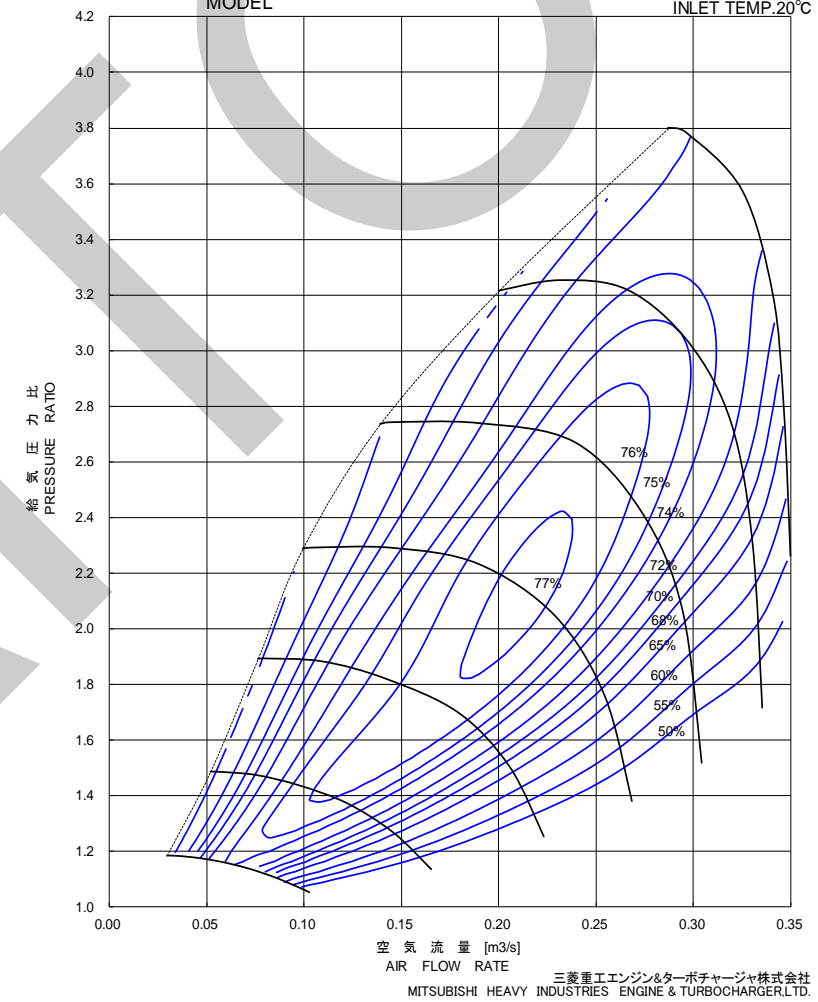
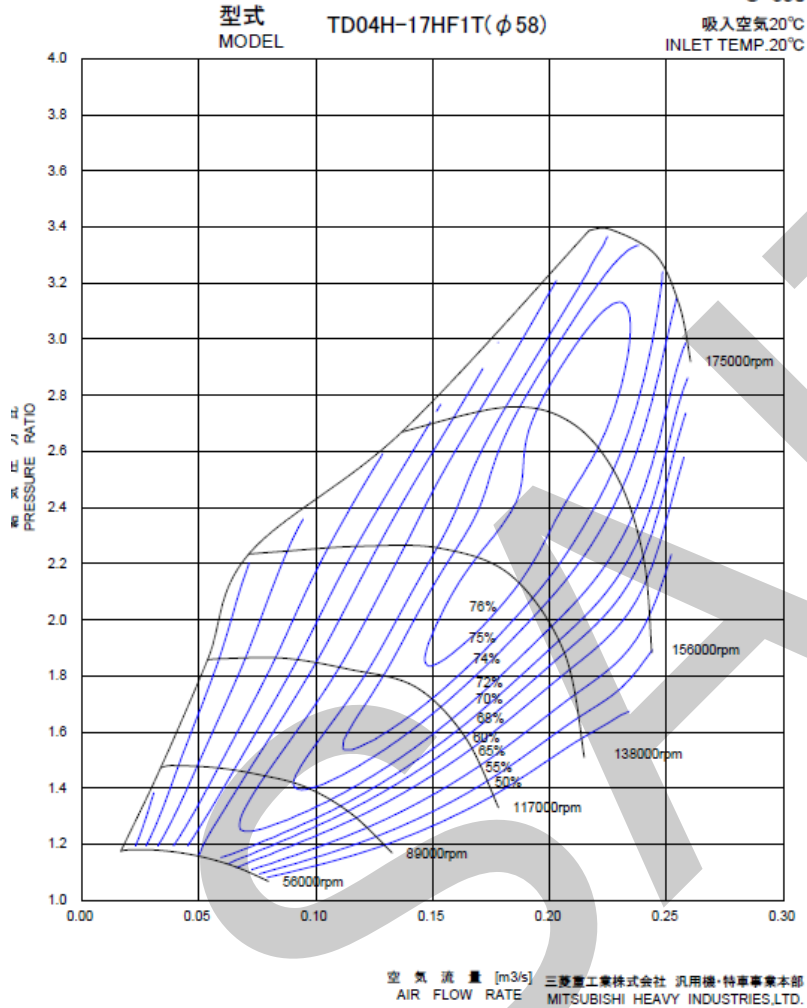

MOVE THE WORLD FORWARD

SAITO

**MITSUBISHI
HEAVY
INDUSTRIES
GROUP**